

Friction Pads

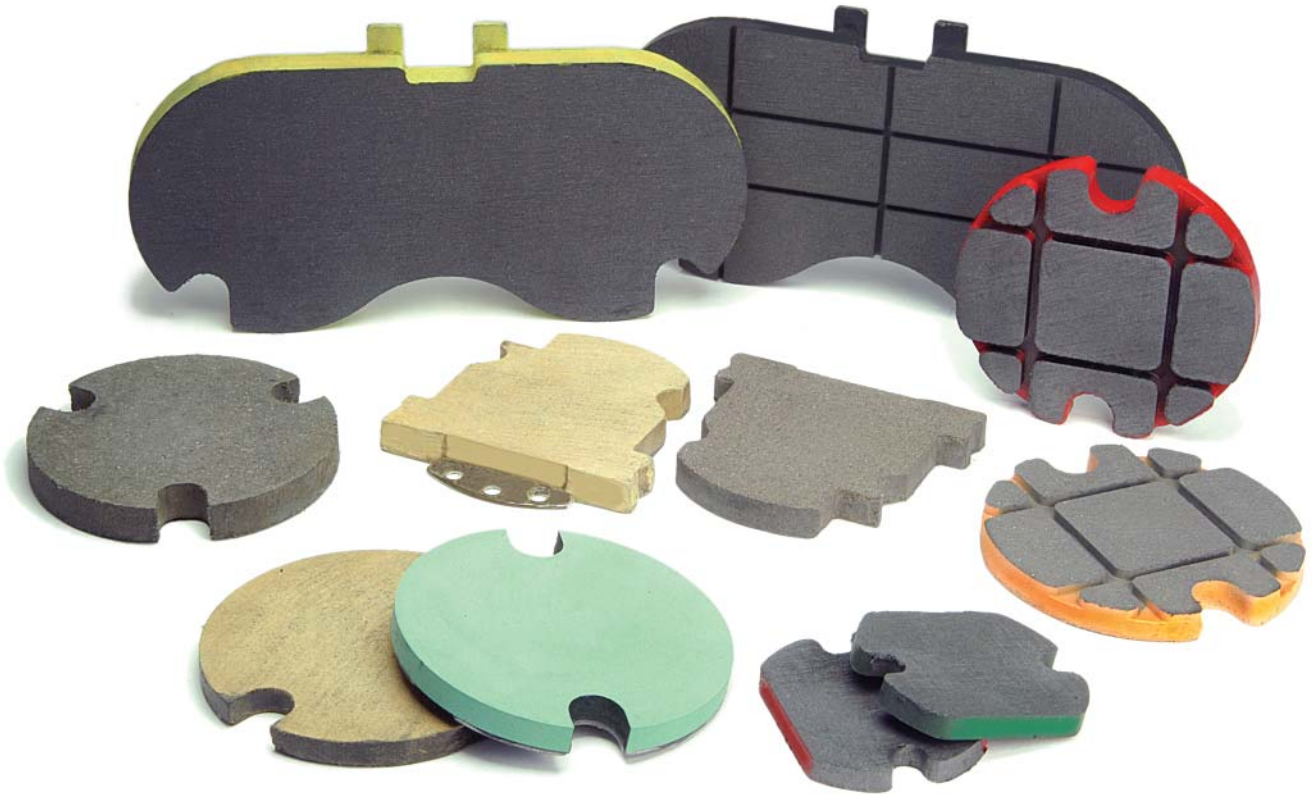

Montalvo Friction Pads

Montalvo friction pads are 100% asbestos free and suitable for use in high temperature applications. The modular design ensures compatibility with all current and older model brakes and clutches. The wide range of friction materials combined with Montalvo's wide range brakes and clutches make it possible to configure a torque range for virtually any application. Montalvo has been offering web tension equipment for over 65 years.

Features & Benefits

- ▶ **The Material** - 100% asbestos free and suitable for use in high temperature applications.
- ▶ **The Backing** - Rigid steel plates optimize pad efficiency.
- ▶ **The Range** - Low, Medium and High friction ratings.
- ▶ **The Fit** - Genuine OEM and replacement part specifications for all Montavo brakes and clutches.

Friction Pads

Dimensions

Standard Series

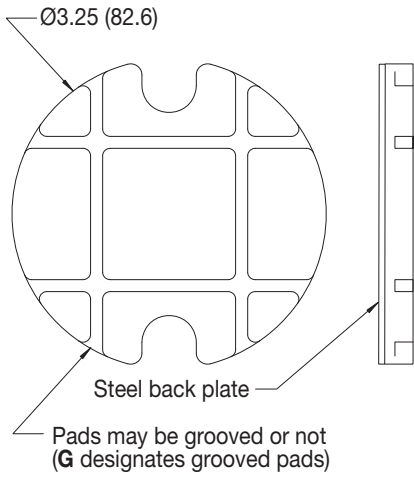

HD Series

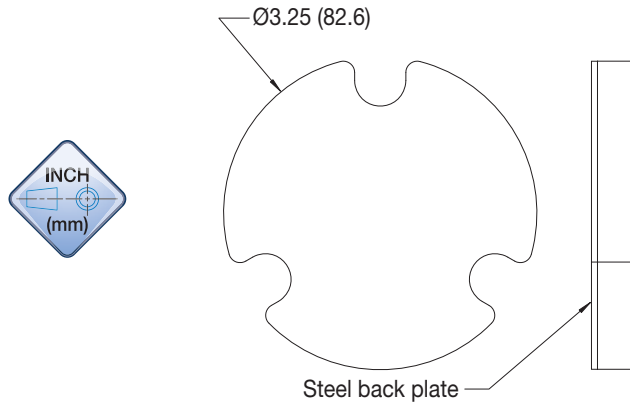

V Series

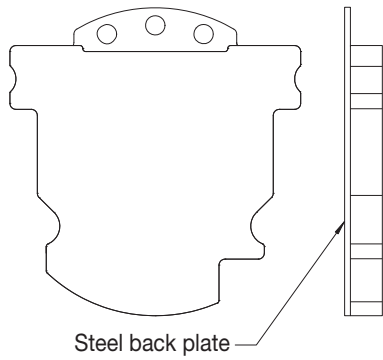

C Series

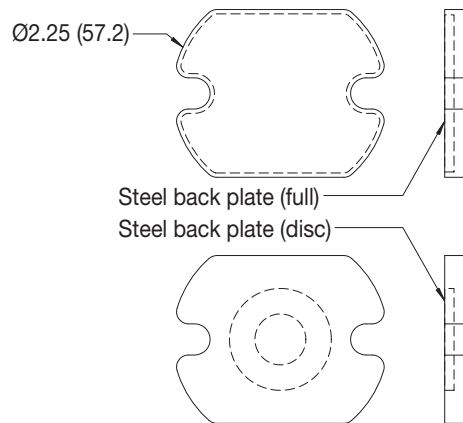

HP Series

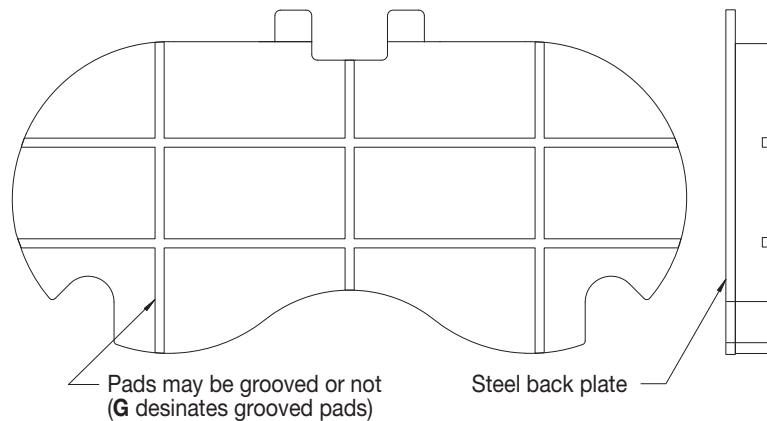

Specifications

Part No.*	Series	Type	Friction	ID*	Painted Edge Color	Base Material
22000070	Standard	4512G	High	H302G	None	Carbon
22000101	Standard	4512GT Anti-Squeal	High	H302G	None	Carbon
22000054	Standard	4511G	High	H301G	Orange	Carbon
22000102	Standard	4511GT Anti-Squeal	High	H301G	Orange	Carbon
22000051	Standard	4514	High	H306	None	Carbon
22000047	Standard	4011G	High	H300G	Blue	Carbon
22000079	Standard	Kevlar +	Medium	H313	Tan (solid)	Kevlar
22000065	Standard	3012G	Medium	M201G	Yellow	Carbon
22000137	Standard	3012G Anti-Squeal	Medium	M201G	Yellow	Carbon
22000066	Standard	3011G	Medium	M200G	Green	Carbon
22000035	Standard	3001	Low	M203	Lt. Green (solid)	Teflon
22000074	Standard	1011G	Low	L100G	Red	Carbon
22000120	C	C4512	High	H302C	None	Carbon
22000013	C	C4511	High	H301C	Orange	Carbon
22000134	C	C3012	Medium	M201C	Yellow	Carbon
22000135	C	C3011	Medium	M200C	Green	Carbon
22000011	C	C3001	Low	M203C	Lt. Green (solid)	Teflon
22000121	C	C1011	Low	L100C	Red	Carbon
22000085	V	V4512	High	H302V	None	Carbon
22000103	V	V4512 Anti-Squeal	High	H302V	None	Carbon
22000083	V	Kevlar +	Medium	H313V	Tan (solid)	Kevlar
22000088	V	V3012	Medium	M201V	Yellow (tab)	Carbon
22000091	V	V3001	Low	M203V	Lt. Green (solid)	Teflon
22000087	V	V1011	Low	L100V	Red (tab)	Carbon
22000139	HP	HP4512G	High	HP302	None	Carbon
22000128	HP	HP4512	High	HP302	None	Carbon
22000132	HP	HP4512 Anti-Squeal	High	HP302	None	Carbon
22000127	HP	HP3012	Medium	HP201	Yellow	Carbon
22000133	HP	HP3012 Anti-Squeal	Medium	HP201	Yellow	Carbon
22000064	HD	HD4512	High	H302H	None	Carbon
22000062	HD	HD4511	High	H301H	Orange	Carbon

* This number is used to help identify your friction pad. It may or may not be imprinted on the friction pad backplate.

Note: **G** indicates pad **TYPES** that have grooves.

Montalvo

Friction Pads

Product Safety

ALWAYS check the brake and/or clutch for proper rotational clearances rotating the unit BY HAND prior to starting the machine. If the unit has been properly installed, all rotating members will turn freely without interference from stationary members (consult the manufacturer's installation instruction manual).

BEFORE starting the machine, be sure that all bearings have been properly lubricated.

NEVER operate any machine without guards in place, or with any obstructions to the brake or clutch unit. NEVER operate a brake or clutch unit with damaged components. Injury may result!

It is recommended that the brake or clutch unit be used with an automatic tension control system to ensure proper air pressure control. Most diaphragm type piston assemblies are rated for a maximum of 75 psi (5 bar). At no time should the operating pressure exceed 100 psi (7 bar). Air pressure should be decreased in a linear fashion from full roll diameter to core. The highest possible pressure should be maintained through out the cycle. Care should be observed when manually regulating air pressure. Consult the manufacturer's engineering specifications for torque vs. air pressure charts and other information.

Many standard brakes and clutches are equipped with valves to control individual cylinder operation. Cylinders may be turned on or off according to the desired tension range. It is beneficial to performance to maintain the highest possible air pressure throughout the operating cycle. If the operating pressure is low, cylinders may be turned off to increase the pressure while maintaining the desired tension level. Various friction pad coefficients are available to optimize pressure range and unit performance. Standard coefficients are High, Medium, and Low. Various friction material compounds are also available to suit specialized applications.

NEVER OPERATE A BRAKE OR CLUTCH UNIT IN ANY WAY OTHER THAN ITS INTENDED FUNCTION. NEVER EXCEED THE OPERATING PARAMETERS SET FORTH BY THE PRODUCT AND ITS APPLICATION. If the operating parameters need to be changed, consult the manufacturer's applications engineering department to verify the proper sizing of the equipment. Montalvo friction materials are rated to operate to a maximum temperature of 350° F (177° C). Consult Montalvo if operating temperatures exceed this rating.

Friction pads should be changed when 0.125" (3,2 mm) of the pad material, including the steel backing plate, remains to be worn. NOTE: Consult product specifications for new material thickness.

When changing friction pads, it is beneficial to sand the cast iron friction discs (rotors) with emery cloth or sand paper. This removes glazing that may have built up during operation. Always wipe the discs with a clean cloth after sanding. Used friction pads may be sanded to remove glazing as well. Always clean the pads of dust prior to re-installation. To maintain acceptable performance levels ALWAYS keep the brake or clutch unit clean and free of grease, paint, water, oil and other foreign substances.

WARNING: Air cooled brakes and clutches operate at extremely high temperatures. NEVER touch a unit during or after operation as severe burns may result. NEVER remove a friction module from a brake or clutch unit with the air supply connected. Injury may result.

Material Safety

- Contains no known carcinogens.
- Are 100% free of asbestos mineral fiber or asbestos by-products.
- Are manufactured from natural and synthetic compounds that cause no known health hazards when used in accordance with operating procedures set forth by Montalvo Incorporated.
- Can be cleaned from the skin of exposed body parts with soap and/or water.
- Will not aggravate existing medical conditions through exposure to the materials, their elements, or their residue.
- Will be screened or contained by approved dust masks or other breathing apparatus in the event that dusting occurs.
- Are fire retardant and can be extinguished with standard fire fighting media in the event that the material is used where an open flame is present.

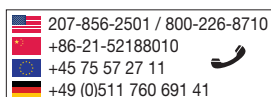

The Montalvo Corporation

EST. 1947

montalvo

Better Web Control®

50 Hutcherson Drive, Gorham, Maine 04038 USA
Fax: 1-800-644-5097 / 207-856-2509

1-800-226-8710 / info@montalvo.com / www.montalvo.com

Technical details subject to change without notice. fricpads-US-03 © Montalvo